



ATD-701

Non-contact Infrared Thermometer Instruction manual



1. Introduction

Compact, rugged and easy to use. Just aim and push the button, read target surface temperatures in less than a second. Safely measure surface temperatures of hot, hazardous or hard-to-reach objects without contact.

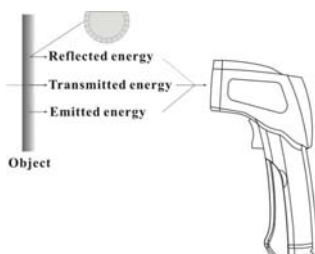

How it works

Infrared thermometer measures the surface temperature of an object. The unit's optics sense emitted, reflected, and transmitted energy which is collect and focused onto a detector. The unit's electronics transmitted energy which is display on the unit. For increased ease and accuracy the laser pointer makes aiming even more precise.

Cautions

Infrared thermometer should be protected from the following:

- EMF (electro-magnetic fields) from arc welders, induction heaters.
- Thermal shock (cause by large or abrupt ambient temperature changes allow 1 hour for unit to stabilize before use).
- Do not leave the unit on or near objects of high temperature.

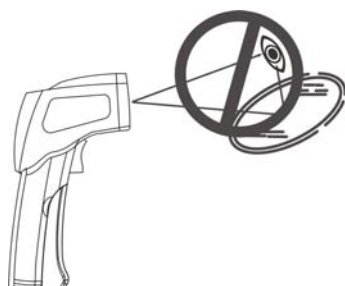

Warning

Do not point laser at eye or indirectly off reflective surfaces.

1. When take measurement, point thermometer toward the object to be measured and hold the red trigger. The object under test should be larger than the spot size calculated by the field of view diagram.
2. Distance & spot size: As the distance from the object increase, the spot size of measuring area becomes larger.

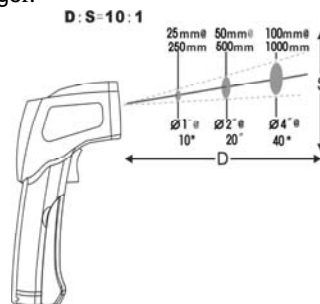

3. Field of view: Make sure the target is larger than the unit's spot size. The smaller the target, the closer measuring distance. When accuracy is critical, make sure the target is at least twice as large as the spot size.
4. Emissivity: Most organic materials and painted or oxidized surfaces have an emissivity of 0.95. Inaccurate readings will result from measuring shiny or polished metal surfaces. To compensate, cover the surface to be measured with masking tape or flat black paint. Measure the tape or painted surface when the tape or painted reach the same temperature as the material underneath.

2. Quick start instruction

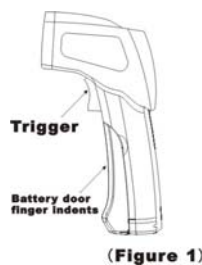

(Figure 1)

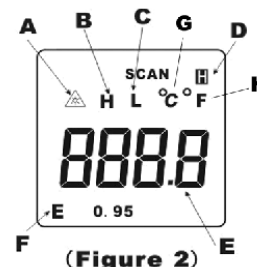

(Figure 2)

1. Press battery door clip, install battery correctly. Pull the trigger, LCD display reading & battery icon. Release the trigger and the reading will hold for 7 seconds.

LCD display:

- A Laser pointer turn on prompt
- B Alarm of high temperature prompt
- C Alarm of Low temperature prompt
- D Data Hold
- E Measure result
- F Emissivity
- G Temperature unit : °C
- H Temperature unit : °F

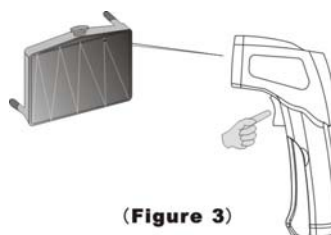

(Figure 3)

- Locating a hot spot aim the thermometer outside the area of interest, then scan across with up and down motions until you locate the hot spot.(please turn on the laser to for accurate measuring)

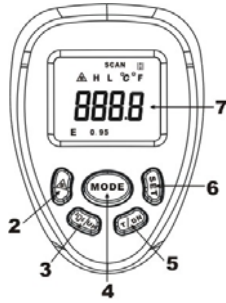

(Figure 4)

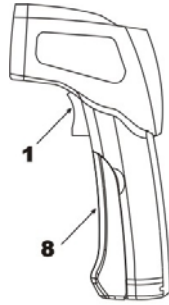

(Figure 5)

3. Diagram description

- Trigger:** Press for turn on, and then display test result and hold data 7 seconds automatically ("HOLD") after unclamping switch. Turn off automatically after 10 seconds without operate.
- Laser pointer button :** press it for turn on laser pointer, press again for turn off.
- Back light /Up button :** In "Alarm temperature" and "setting emissivity" mode for adjust value up. In other mode for turn on back light. When product working, press it for turn on back light, press again for turn off.
- MODE button :** Press MODE button for cycle options - MAX - AVG - MIN -HAL -LAL mode
 A. MAX : Measure maximum data current ;
 B. MIN : Measure minimum data current ; ;
 C. AVG : Calculate the average of all measure data ;
 D. HAL : Alarm of high temperature. Option HAL mode, press "UP or DN" button for set alarm temperature. When LCD display "H" means measure result exceeded the alarm temperature ;
 E. LAL : Alarm of low temperature. Option HAL mode, press "UP or DN" button for set alarm temperature. When LCD display "L" means measure result under the alarm temperature ;
- T/ DN button :** In "Alarm temperature" and "setting emissivity" mode for adjust value down . When turn on product and press direct for °C/ □ select.
- SET button :** Press for setting emissivity. And press "UP or DN" for adjust from 0.1~1.0. Press SET button again for exit setting mode.
- LCD display**
- Battery door:** When replace battery, please using the finger indents to pull open the battery door.

3. Maintenance

- Lens cleaning: Blow off lose particles using clean compressed air. Gently brush remaining debris away with a moist cotton cloth.
- Case cleaning: Clean the case with a damp sponge/cloth and mild soap.
- Please take out the battery when not using for a long time.

Note:

- Do not use solvent to clean lens.
- Do not submerge the unit in water.

4. Specifications

Temperature range	Infrared : -30°C to 550°C(-22 to 1022°F)
Accuracy	±3°C or ±3% of rdg, -30°C to 0°C(-22 to 32□) ±2°C or ±2% of rdg, 0°C to 100°C(32 to 212°F) ±3°C or ±3% of rdg, ≥100°C(212°F)
Display spot size	10:1
Repeatability	1% of reading or ±1°C
Response time	500ms
Spectral response	8-14um
Emissivity	0.1 ~ 1.0 adjustable
Relative humidity	10-95% RH non-condensing
Operating temperature	0°C to ~60°C(32 to 140°F)
Storage temperature	-20~60°C(-4~140°F) without battery
Power Supply	9V 6F22 battery
Battery life	Laser models:12 hrs
Product size	165×80×41mm
Product weight	155g (without battery)

Note:

Display "AL" means ambient temp lower than 0□;
 Display "AH" means ambient temp higher than 60°C";
 Display above code in normal ambient temp, probable means this meter was broken.

Attached list : Applicable Emissivity for Different Material (For reference only)

Material	Emissivity	Material	Emissivity
Aluminum	0.30	Iron	0.70
Asbestos	0.95	Lead	0.50
Asphalt	0.95	Limestone	0.98
Basalt	0.70	Oil	0.94
Brass	0.50	Paint	0.93
Brick	0.90	Paper	0.95
Carbon	0.85	Plastic	0.95
Ceramic	0.95	Rubber	0.95
Concrete	0.95	Sand	0.90
Copper	0.95	Skin	0.98
Dirt	0.94	Snow	0.90
Frozen food	0.90	Steel	0.80
Hot Food	0.93	Textiles	0.94
Glass(plate)	0.85	Water	0.93
Ice	0.98	Wood	0.94

